

# PATRIOT-AT2 LIFT

U.S. PATENT NO'S: [7,249,386 B2] [D507,769 S]

\*MEASUREMENT TAKEN WITH THE LIFT AT FULL LOAD\*

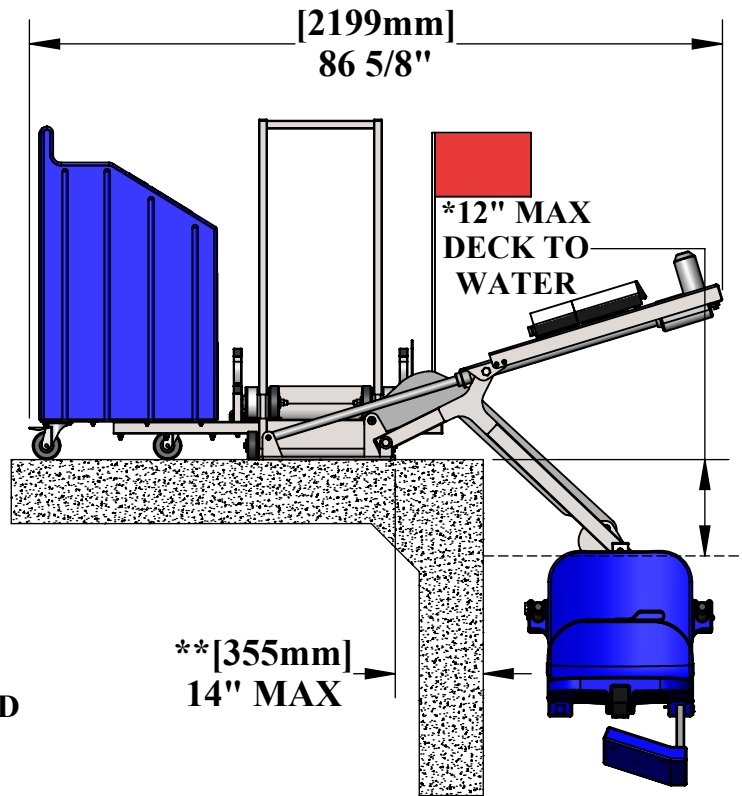
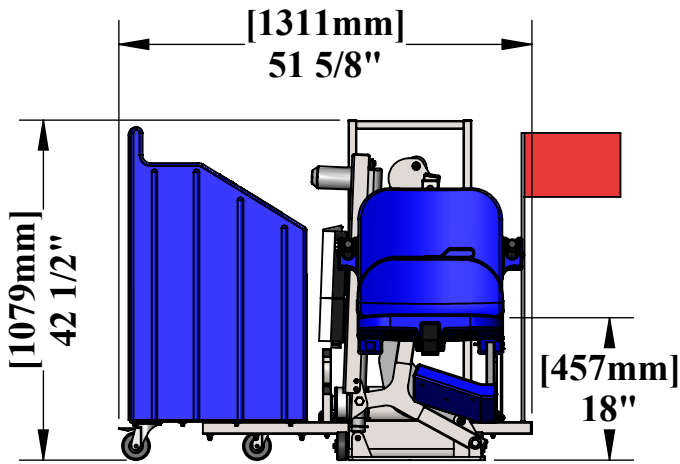

PRODUCT WEIGHT: 275lbs [124kg]  
 MAX WEIGHT CAPACITY: 375lbs [170kg]  
 \*\*MIN SETBACK: 9"  
 \*\*MAX SETBACK: 14"  
 \*MAX WATER DRAFT: \*12"  
 ADA COMPLIANCE: THIRD PARTY VERIFIED  
 BY WYLE LABS  
 STOWED WIDTH: 35 1/4" (W/O FOOTREST)

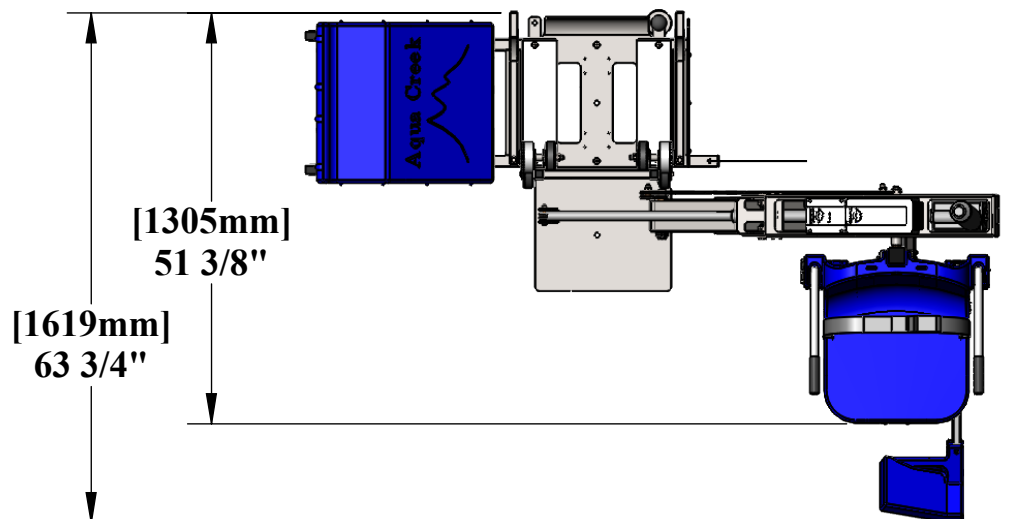
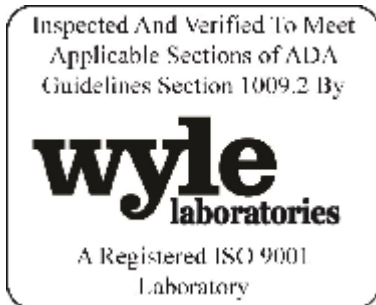

9889 GARRYMORE LANE  
 MISSOULA, MT 59808  
 (406) 549-0769  
 FAX (406) 549-2602

NOTE:  
 \*SPECIFICATIONS ARE SUBJECT TO CHANGE WITHOUT NOTICE

PRODUCT:	PATRIOT-AT2		
PART #:	F-12PPL-HD-AT2		
SCALE:	1:24	DATE:	1/18/2018
DRAWN BY:	KR	REVISION:	A